

STAINLESS STEEL 304 PRESS FIT FITTINGS (M PROFILE)



A Product of the nPressGuard® Solution



COMPLY WITH BSEN1254-2: 1998

FI 90° ELBOW

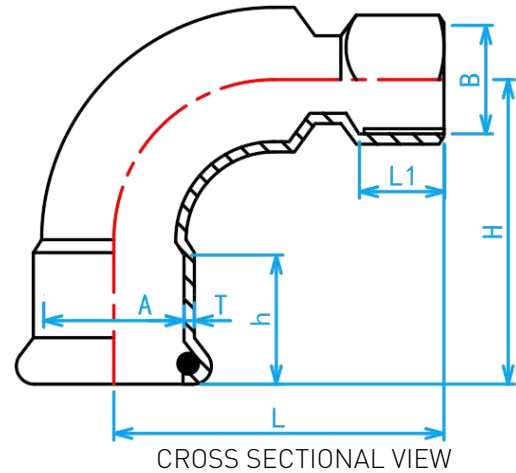

DIMENSIONS

SKU	A×B (mm × inch)	L (mm)	H (mm)	h (mm)	L1 (mm)	T (mm)	WEIGHT (kg)	PCS/CTN
SSPFNFIE01515	15×1/2" BSP	43	43	20	15.5	1.5	0.060	300
SSPFNFIE02015	22×1/2" BSP	43	50	21	15.5	1.5	0.078	160
SSPFNFIE02020	22×3/4" BSP	48	50	21	16.0	1.5	0.090	160
SSPFNFIE02515	28×1/2" BSP	68	60	23	15.5	1.5	0.115	160
SSPFNFIE02520	28×3/4" BSP	55	60	23	16.0	1.5	0.128	80
SSPFNFIE02525	28×1" BSP	62	60	23	20.0	1.5	0.146	70
SSPFNFIE03515	35×1/2" BSP	76	72	26	15.5	1.5	0.165	60
SSPFNFIE03520	35×3/4" BSP	76	72	26	16.0	1.5	0.170	60
SSPFNFIE03525	35×1" BSP	65	72	26	20.0	1.5	0.195	60
SSPFNFIE03525M*	35×1" BSP	78	72	26	20.0	1.5	0.210	50
SSPFNFIE03525L	35×1" BSP	80	90	26	20.0	1.5	0.230	40
SSPFNFIE03535	35×1 1/4" BSP	68	72	26	22.0	1.5	0.235	80
SSPFNFIE04215	42×1/2" BSP	86	85	31	15.5	1.5	0.165	30
SSPFNFIE04220	42×3/4" BSP	83	85	31	16.0	1.5	0.233	30
SSPFNFIE04225	42×1" BSP	90	85	31	20.0	1.5	0.260	30
SSPFNFIE04235	42×1 1/4" BSP	98	85	31	22.0	1.5	0.278	30
SSPFNFIE04242	42×1 1/2" BSP	80	85	31	25.0	1.5	0.300	30
SSPFNFIE05015	54×1/2" BSP	97	105	35	15.5	1.5	0.337	21
SSPFNFIE05020	54×3/4" BSP	100	105	35	20.0	1.5	0.345	25
SSPFNFIE05025	54×1" BSP	102	105	35	22.0	1.5	0.378	25
SSPFNFIE05035	54×1 1/4" BSP	106	105	35	24.0	1.5	0.403	25
SSPFNFIE05042	54×1 1/2" BSP	100	105	35	25.0	1.5	0.396	25
SSPFNFIE05050	54×2" BSP	93	105	36	25.0	1.5	0.460	30
SSPFNFIE06565	67×2 1/2" BSP	133	143	50	28.0	1.8	0.970	15

*This item requires special ordering. Please consult with a salesperson for the estimated lead time.